

Audio monitor speaker signals often contain unwanted noise that is distracting to performers between musical selections or when the monitors are not in use. Examples include ambient pickup from live microphones or hum from instruments. During periods when it is desired to mute the monitors, users may manually turn them off using the RDL ST-SSR1 solid-state audio switch module (use 2 for stereo as shown). The RDL RT-2 remote control may be mounted in any convenient location (podium mounted, wall mounted). This application may be used to mute the audio inputs to power amplifiers feeding either fixed or portable monitor speakers. This application is ideal for church choir monitors or any performance area using stage monitors.

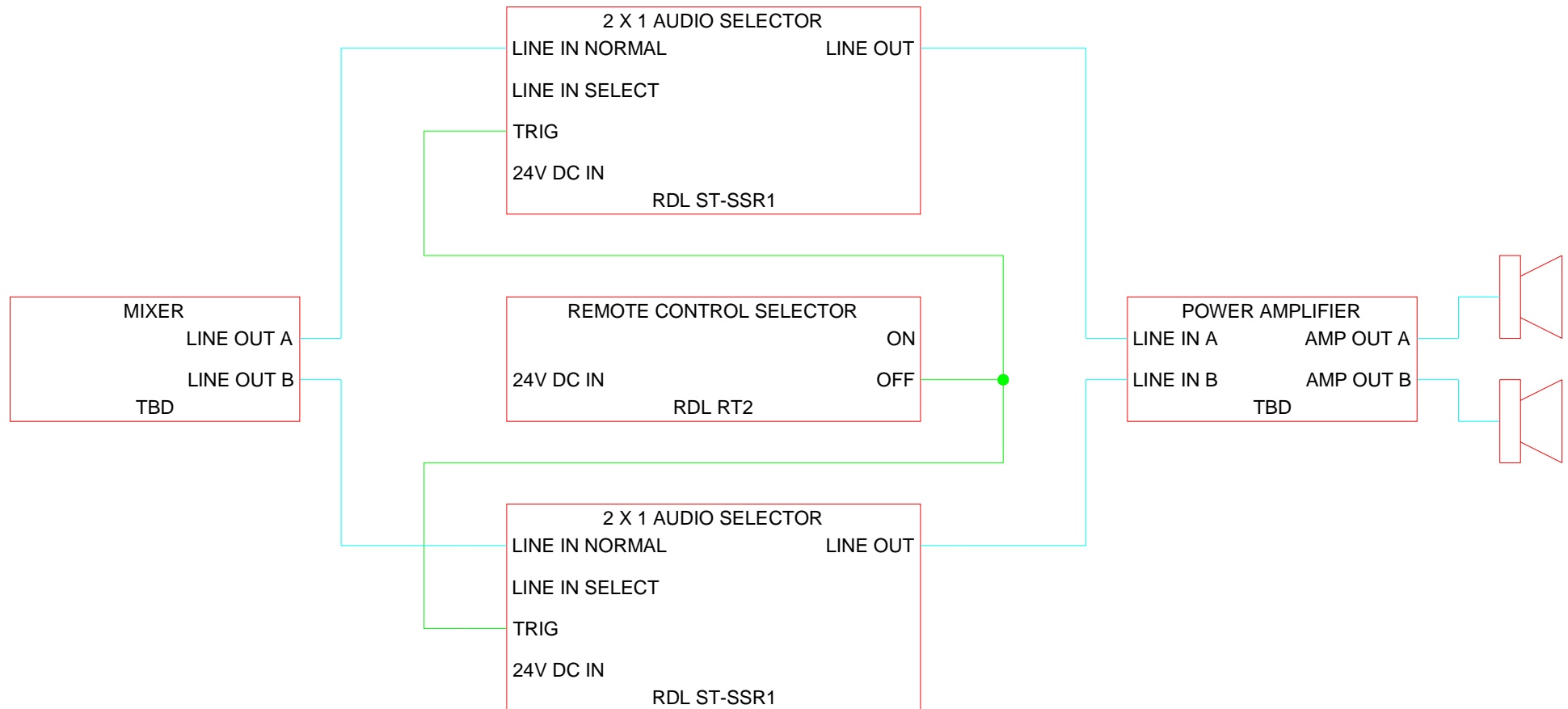

### RDL PRODUCTS

1 <a href="#">RT2</a>	Remote Control Selector	<a href="#">RT2</a>	Fernsteuerung	<a href="#">RT2</a>	Control Remoto Selector	<a href="#">RT2</a>	Sélecteur de contrôle à distance
2 <a href="#">ST-SSR1</a>	Solid-State "Relay" Audio Switch	<a href="#">ST-SSR1</a>	Elektronisches Relais	<a href="#">ST-SSR1</a>	Relé de Transistor	<a href="#">ST-SSR1</a>	Relais Audio Electronique